



Zonge Electrical Tomography Acquisition System

For a number of years, Zonge International has been involved in the development of instruments for electrical resistance tomography (ERT) in connection with ongoing research and development at the Lawrence Livermore National Laboratory, a facility funded by the U.S. Department of Energy. ERT is being used to generate resistivity images of the “plane” defined by the space between two boreholes or other electrode strings. ERT is presently being applied to monitor leakage at hazardous waste sites, to monitor dynamic fluid injection processes that are often involved in waste site remediation. Other applications for ERT technology exist and are simply waiting for the availability of equipment and software that can economically acquire the necessary resistivity data required and the software required for its interpretation.

ERT involves the acquisition of hundreds, even thousands of 4-electrode resistivity measurements that are possible between multiple strings of electrodes. For example, given two strings of 15 equally-spaced electrodes (30 electrodes total), there are 632 different dipole-dipole measurements that can be made (including all reciprocal measurements) involving transmitter and receiver dipoles with a fixed length of 2 electrode spacings. The dense data provide the basis for solving sophisticated inverse computer models of the conductivity distribution in the ground. When both resistivity and IP are measured, the resulting data set relates to the complex *impedance* of the earth and the term EIT (Electrical Impedance Tomography) is sometimes used to describe the technique.

Obviously, there are too many measurements to be acquired manually. To efficiently measure all the desired transmitter-receiver electrode combinations requires a computerized acquisition system that automatically switches both transmitter and receiver electrodes and has multi-channel measurement capabilities. The Zonge ERT/EIT acquisition system has unique capabilities for the efficient acquisition of ERT or EIT data sets. With the Zonge ERT/EIT system, acquisition of the dense data sets is now economically feasible. Such data sets are required to generate conductivity images using sophisticated inversion software. These capabilities greatly improve the usefulness of the venerable resistivity measurement for problems wherein the resistivity method is traditionally applied. Moreover, the capability of ERT/EIT to generate “images” of conductivity distribution greatly expands the applicability of the electrical resistivity method to many problems in engineering and hazardous waste site characterization and monitoring, and in geophysical and groundwater exploration as well.

ERT Acquisition System

The system developed by Zonge (see Figure 1) includes the following equipment:

1. GDP-32 Multi-Function Receiver
2. MX-30 Electrode Multiplexor
3. ZT-30 12-120Vdc Transmitter
4. ISO/1 Isolation Amplifier
5. Laptop PC with ZETA Acquisition Control

GDP-32 Multi-Function Receiver – The GDP-32 is a general-purpose multi-function instrument capable of making both frequency-domain and time-domain resistivity/IP and EM measurements. For ERT data acquisition, the firmware in the GDP-32 has been modified so that resistivity measurements can be performed under the control of an external controller by means of commands sent to it through the serial data port. The GDP-32 can be configured so that as many as 16 independent analog channels can be measured simultaneously.

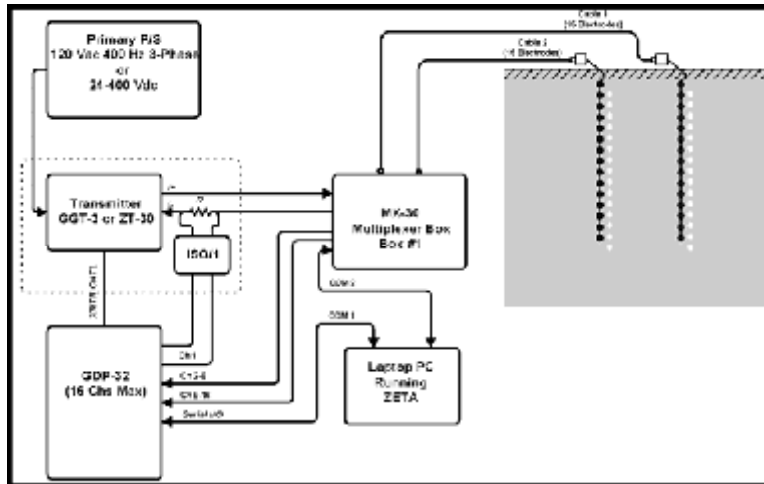

Figure 1: Function block diagram of a Zonge ERT system.

MX-30 Electrode Multiplexer – The MX-30 performs two multiplexing functions under external control. First, it is able to switch each of the two transmitter lines to one of 30 possible electrodes. Secondly, it is able to select any pair of electrodes not connected to a current electrode and route the differential signal to one of 16 possible differential output channels. The MX-30 is configured with commands received through a serial RS-232C data port.

ZT-30 Transmitter – The ZT-30 is the smallest Zonge transmitter available. It is suitable for small-scale ERT surveys (electrode dipole sizes of 2-3 m). The power supply may be as simple as one or more 12 Vdc storage batteries in series. Any DC power supply with a voltage of 400 Vdc or less and an output current of less than 5 Amps can be used. The GDP-32 is able to switch the transmitter current ON and OFF as well as to commutate its polarity at the chosen frequency.

ISO/1¹ – A current-regulated transmitter is not appropriate for ERT because the resistive load produced by the grounding resistance of the transmitter electrode-pair can vary widely. The **ISO/1** isolation amplifier is used to sense the voltage drop across a current-sensing resistor. This signal is routed to one of the GDP-32 receiver channels where it is scaled by the value of the sensing resistor so that the measured receiver dipole voltages can be normalized by current.

Laptop PC – The system is controlled by a computer running Windows 95 or NT with two serial ports. The proprietary Zonge ERT control and acquisition software (ZETA) configures the MX-30, connecting the transmitter to the appropriate electrode pair and routing the receiver dipoles to the GDP-32. ZETA uses a predefined “schedule” consisting of a list of MX-30 configurations. A schedule is a text file that can be generated using user-developed software. ZETA can generate simple dipole-dipole schedule files. Measurements from one MX-30 configuration are transferred to the computer for formatting and storage, and the next configuration is automatically setup and measured.

An 8-ch GDP-32 can acquire approximately 500-1000 dipole-dipole measurements per hour.²

¹ Early systems used a separate isolation amplifier to provide an electrically isolated voltage proportional to the current waveform for the receiver to measure. The latest version of the ZT-30 includes an appropriate sense resistor and isolation amplifier so that a separate amplifier, the ISO/1, is not required.

² Acquisition productivity depends on a number of parameters including frequency measured, number of data stacks, and whether or not the MX-30 configuration schedule has been “optimized”. Naturally, the time may be reduced considerably by adding receiver channels (16 channels maximum).

Roll-Along Dipole-Dipole Resistivity/IP

Dipole-dipole resistivity and IP surveys are routinely acquired in mining exploration. In many mining applications dipole lengths can be as large as long as 300 m and in rare cases even 600 m. The advantage of the dipole-dipole method is that it provides both profiling and depth-sounding information in a systematic way. The dipole-dipole survey technique can also be applied in engineering, groundwater, and hazardous waste site applications, usually on a much smaller scale (5-10m dipole lengths). But even at scales of a few meters, the logistics of collecting dipole-dipole data out to $n = 6$ are considerable and, consequently, the cost of a dipole-dipole profile may be prohibitive. However, using the Zonge ERT system, the economics of high-density dipole-dipole resistivity and IP profiling for small-scale engineering and waste site characterization become more reasonable. Figure 2 is a block diagram of a system used for acquisition of high-density dipole-dipole resistivity and IP. With this system, Zonge has demonstrated that it can acquire dipole-dipole data with 15-ft dipoles at 7.5-ft move-out intervals out to a maximum spacing of 90 ft. (dipole n-spacings from 0.5 to 6) at a rate of 2000 line-ft per day.

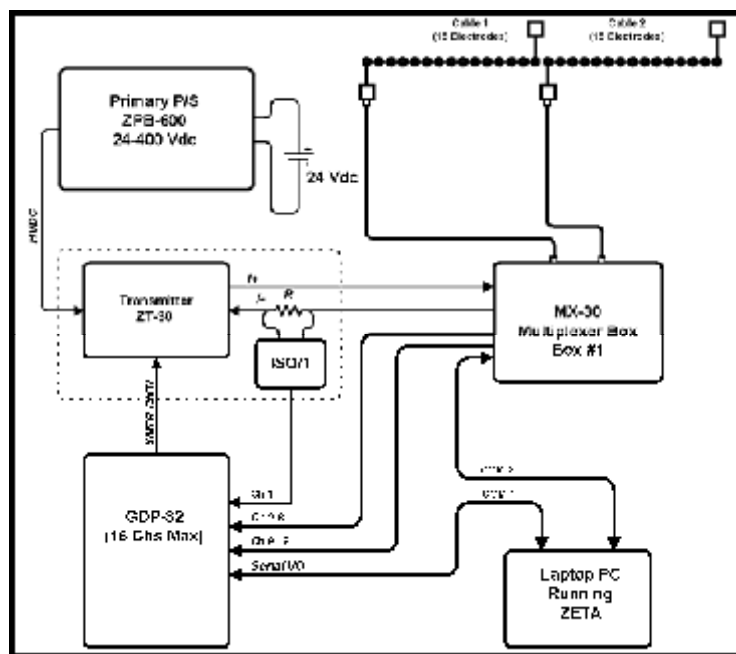

Figure 2: Function block diagram for a Zonge system for roll-along dipole-dipole resistivity and IP.

Data Interpretation

Data Quality Control: There is no way of viewing the resulting data graphically in order to evaluate data quality. The only measure of data quality is the degree to which reciprocal measurements agree.³ The data files are sorted and filtered according to a user-specified reciprocity error threshold. The remaining measurements are then used as the observed data for inversion and display.

³ Reciprocal measurements are measurements in which the transmitter electrodes and the receiver electrodes have been interchanged. Thus the electrode geometry remains the same. Ideally, reciprocal measurements should be identical.

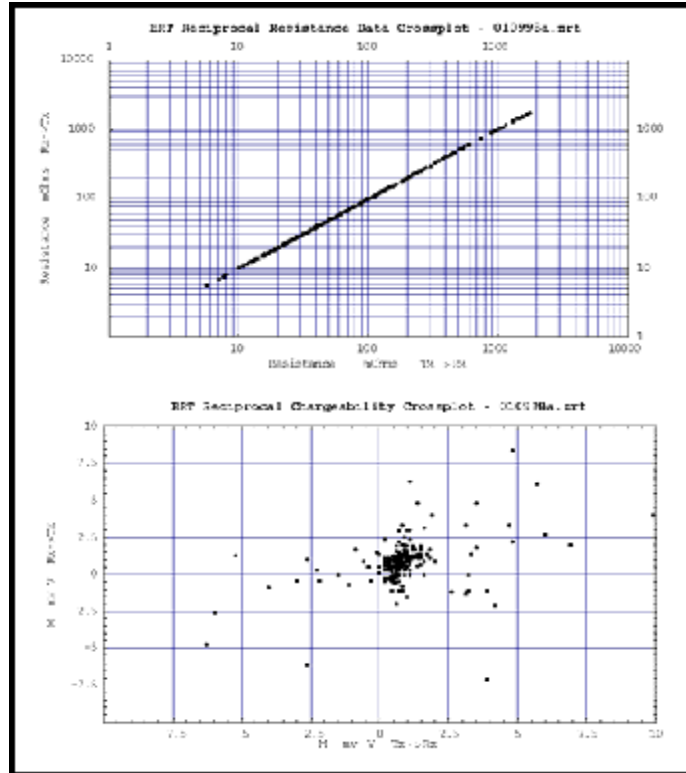

Figure 3: Crossplots that summarize the quality of an ERT data set based on reciprocity.

2-Dimensional Inversion: Two-dimensional ERT inversion provides estimates of the resistivity distribution in the “plane” defined by the cross-sectional area between two drill holes. A 2-D inversion algorithm is based on the assumption that there is no variation in resistivity in the direction normal to the image plane. Zonge has developed a proprietary 2-D inversion program (TS2DIP) that can invert a typical “plane” of ERT data (i.e., 2 boreholes, each with 15 electrodes) in less than an hour on a 166MHz Pentium PC. Lawrence Livermore National Laboratory has developed a similar algorithm for 2-D inversion. The LLNL program can be licensed for use by outside parties by contacting Lawrence Livermore Laboratories directly.⁴ This program can also invert extended surface profiles involving hundreds of electrodes.

3-Dimensional Inversion: In many cases, the 2-D assumption is not valid. But experience has shown that the resulting resistivity image nonetheless provides useful qualitative and semi-quantitative information about the subsurface distribution of resistivity. A fully 3-D imaging technique based on data obtained from 4 or 5 drill holes located on a grid (4-spot; 5-spot) magnifies the problem of inversion to the point where it is presently impractical on a PC. Lawrence Livermore has developed a program that runs on a workstation that can invert a 5-spot data set overnight. Other groups are working to develop similar 3-D inversion codes that run on high-performance workstations. To our knowledge, none of these inversion codes are commercially available.

⁴ Contact William Daily or Abelardo L. Ramirez:
Lawrence Livermore National Laboratory
P.O. Box 808, L-206
Livermore, CA 94550

510 422-6909 (tel.)
510-422-3118 (FAX)
email: ramirez3@llnl.gov